

Grizzly **Industrial, Inc.**®

24" WET & DRY CUTTING TOOL GRINDER

MODEL G9960

INSTRUCTION MANUAL

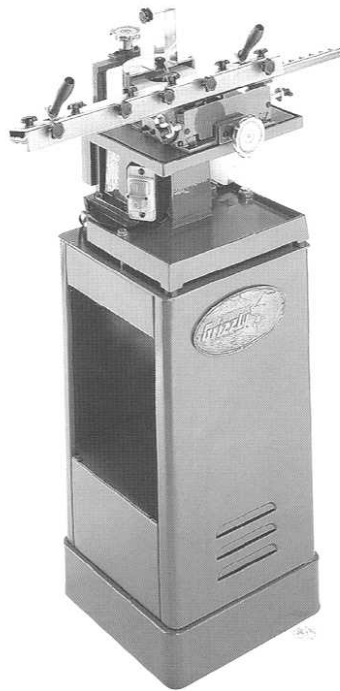

COPYRIGHT©2000 BY GRIZZLY INDUSTRIAL, INC.
**WARNING: NO PORTION OF THIS MANUAL MAY BE REPRODUCED IN ANY SHAPE
OR FORM WITHOUT THE WRITTEN APPROVAL OF GRIZZLY INDUSTRIAL, INC.**
PRINTED IN TAIWAN.

TABLE OF CONTENTS

Table Of Contents

PAGE

1. Safety

Safety instructions for power tools	1~2
Additional safety instructions for grinders	3

2. Circuit requirements

110V Operation	4
Fusing	4
Extension cords	4
Grounding	4

3. Introduction

Commentary	5
Getting to know your grinder	6
Specifications	7
Operating instructions	8~12
How to adjust the cooling water	8
How to change the grinding wheels	8
How to dress the grinding wheels	9
How to sharpen planer/jointer knives	10~11
How to sharpen chisels	11
How to sharpen drill bits	12

Warranty and returns	13
-----------------------------------	----

Parts diagram	14
----------------------------	----

Parts list	15
-------------------------	----

SECTION 1: SAFETY

WARNING

For Your Own Safety Read Instruction Manual Before Operating This Equipment

The purpose of safety symbols is to attract your attention to possible hazardous conditions. This manual uses a series of symbols and signal words which are intended to convey the level of importance of the safety messages. The progression of symbols is described below. Remember that safety messages by themselves do not eliminate danger and are not a substitute for proper accident prevention measures.



Indicates an imminently hazardous situation which, if not avoided, WILL result in death or serious injury.



Indicates a potentially hazardous situation which, if not avoided, COULD result in death or serious injury.



Indicates a potentially hazardous situation which, if not avoided, MAY result in minor or moderate injury. It may also be used to alert against unsafe practices.

NOTICE

This symbol is used to alert the user to useful information about proper operation of the equipment.

WARNING

Safety Instructions For Power Tools

1. **KEEP GUARDS IN PLACE** and in working order.
2. **REMOVE ADJUSTING KEYS AND WRENCHES.** Form habit of checking to see that keys and adjusting wrenches are removed from tool before turning on.
3. **KEEP WORK AREA CLEAN.** Cluttered areas and benches invite accidents.
4. **DON'T USE IN DANGEROUS ENVIRONMENT.** Don't use power tools in damp or wet locations, or where any flammable or noxious fumes may exist. Keep work area well lighted.
5. **KEEP CHILDREN AND VISITORS AWAY.** All children and visitors should be kept a safe distance from work area.
6. **MAKE WORK SHOP CHILD PROOF** with padlocks, master switches, or by removing starter keys.
7. **DON'T FORCE TOOL.** It will do the job better and safer at the rate for which it was designed.
8. **USE RIGHT TOOL.** Don't force tool or attachment to do a job for which it was not designed.

WARNING

Safety Instructions For Power Tools

9. **USE PROPER EXTENSION CORD.** Make sure your extension cord is in good condition. Conductor size should be in accordance with the chart below. The amperage rating should be listed on the motor or tool nameplate. An undersized cord will cause a drop in line voltage resulting in loss of power and overheating. Your extension cord must also contain a ground wire and plug pin. Always repair or replace extension cords if they become damaged.

Minimum Gauge for Extension Cords

AMP RATING	LENGTH		
	25ft	50ft	100ft
0-6	18	16	16
7-10	18	16	14
11-12	16	16	14
13-16	14	12	12
17-20	12	12	10
21-30	10	10	No

10. **WEAR PROPER APPAREL.** Do not wear loose clothing, gloves, neckties, rings, bracelets, or other jewelry which may get caught in moving parts. Non-slip footwear is recommended. Wear protective hair covering to contain long hair.
11. **ALWAYS USE SAFETY GLASSES.** Also use face or dust mask if cutting operation is dusty. Everyday eyeglasses only have impact resistant lenses, they are NOT safety glasses.
12. **SECURE WORK.** Use clamps or a vise to hold work when practical. It's safer than using your hand and frees both hands to operate tool.

13. **DON'T OVERREACH.** Keep proper footing and balance at all times.
14. **MAINTAIN TOOLS WITH CARE.** Keep tools sharp and clean for best and safest performance. Follow instructions for lubricating and changing accessories.
15. **DISCONNECT TOOLS** before servicing and changing accessories, such as blades, bits, cutters, and the like.
16. **REDUCE THE RISK OF UNINTENTIONAL STARTING.** Make sure switch is in off position before plugging in.
17. **USE RECOMMENDED ACCESSORIES.** Consult the owner's manual for recommended accessories. The use of improper accessories may cause risk of injury.
18. **CHECK DAMAGED PARTS.** Before further use of the tool, a guard or other part that is damaged should be carefully checked to determine that it will operate properly and perform its intended function. Check for alignment of moving parts, binding of moving parts, breakage of parts, mounting, and any other conditions that may affect its operation. A guard or other part that is damaged should be properly repaired or replaced.
19. **NEVER LEAVE TOOL RUNNING UNATTENDED. TURN POWER OFF.** Don't leave tool until it comes to a complete stop.

WARNING

Additional Safety Instructions For Grinders

1. Wear a face shield and/or safety goggles.
2. Use clamps and supports to sharpen tools.
3. Grinding creates sparks. make sure your work area is free of combustible materials.
4. Dress the grinding wheel when its surface becomes ruttled or uneven. Replace the wheel if the wear or damage becomes excessive.
5. Do not use a wheel that is cracked or chipped.
6. Be sure the grinder is mounted on a stable surface.
7. If you are unclear about operating the machine, don't do it. Please call our service department if you have questions about any element of this machine's operation.
8. Use care when handling sharpened cutting tools.

WARNING

Like all power tools, there is danger associated with the Model G9960 Universal Knife Grinder. Accidents are frequently caused by lack of familiarity or failure to pay attention. Use this tool with respect and caution to lessen the possibility of operator injury. If normal safety precautions are overlooked or ignored serious personal injury may occur.

CAUTION

No list of safety guidelines can be complete. Every shop environment is different. Always consider safety first, as it applies to your individual working conditions. Use this and other machinery with caution and respect. Failure to do so could result in serious personal injury, damage to equipment or poor work results.

WARNING

Operating this equipment has the potential for flying debris to cause eye injury. Always wear safety glasses or goggles when operating equipment. Everyday glasses or reading Glasses only have impact resistant lenses, they are not safety glasses. Be certain the safety glasses you wear meet the appropriate standards of the American National Standards Institute (ANSI).

SECTION 2 : CIRCUIT REQUIREMENTS

110V Operation

The Model G9960 is wired for 110/120V, single phase operation only. The 1/2 HP, 3450 RPM motor draws 8 amps. This is not a large load. However, if you operate the grinder on a circuit that is already close to capacity, it could overload that circuit. If an unusual load does not exist and a power failure still occurs, contact a qualified electrician or our service department.



Fusing

A 15-amp fuse or circuit breaker should be used when fusing the wet & dry cutting tool grinder. Circuits rated any higher are not adequate to protect the motor from power surges.

Equipment returned to us for service that shows evidence of being over-fused will be repaired or replaced totally at the customer's expense, regardless of the present warranty status.



Extension Cords

If you find it necessary to use an extension cord with the Model G9960 make sure the cord is rated Hard Service (grade S) or better. Refer to the chart in the standard safety instructions to determine the minimum gauge for the extension cord. The extension cord must also contain a ground wire and plug pin. Always repair or replace extension cords when they become worn or damaged.



Grounding

In the event of an electrical short, grounding reduces the risk of electric shock by providing a path of least resistance to disperse electric current. This tool is equipped with a power cord having an equipment-grounding conductor. The outlet must be properly installed and grounded in accordance with all local codes and ordinances.

!WARNING

This equipment must be grounded. Verify that any existing electrical outlet and circuit you intend to plug into is actually grounded. If it is not, it will be necessary to run a separate 12 A.W.G. copper grounding wire from the outlet to a known ground. Under no circumstances should the grounding pin from any three-pronged plug be removed. Serious personal injury may occur.

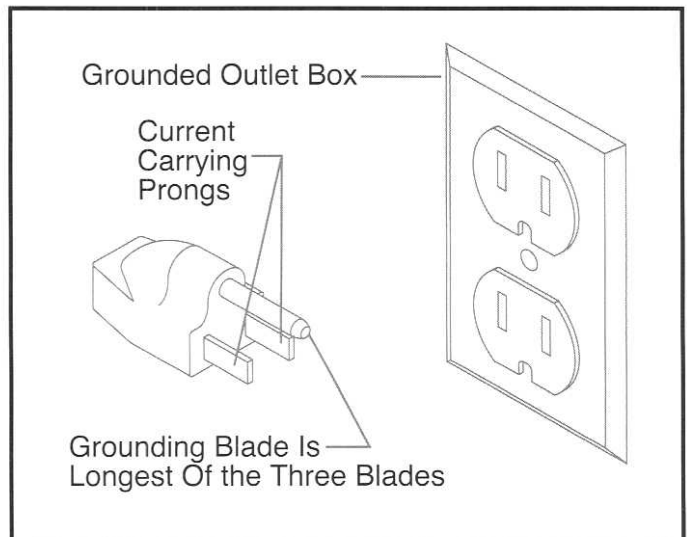

Figure 1. Grounded plug configuration.



SECTION 3: INTRODUCTION

Commentary

We are proud to offer the Grizzly Model G9960 wet & dry cutting tool Grinder. The Model G9960 is part of a growing Grizzly family of fine woodworking machinery. When used according to the guidelines set forth in this manual, you can expect years of trouble-free, enjoyable operation and proof of Grizzly's commitment to customer satisfaction.

The Model G9960 is designed for heavy-duty professional use. It features a capacitor-start $\frac{1}{2}$ HP motor that operates on 110V at 3450 RPM. It is capable of sharpening jointer and planer knives up to 24" long. Its work table adjusts from 0° to 90° to accommodate a wide range of cutting angles. Overall shipping weight of the Model G9960 is approximately 180 lbs.

A number of optional accessories for the Model G9960 are available through the Grizzly catalog. They include a diamond dressing tool and replacement stones in green color silicon carbide grinding wheel.

We are also pleased to provide this manual with the Model G9960 it was written to guide you through assembly, review safety considerations, and cover general operating procedures. It represents our effort to produce the best documentation possible. If you have any comments regarding this manual, please write to us at the address below:

Grizzly Industrial, Inc.
% Technical Documentation
P.O. Box 2069
Bellingham, WA 98227-2069

Most importantly, we stand behind our machines. If you have any service questions or parts requests, please call or write us at the location listed below.

Grizzly Industrial, Inc.
2406 Reach Road
Williamsport, PA 17701
Phone: (570) 326-3806
Fax: (800) 438-5901
E-Mail: techsupport@grizzlyindustrial.com
Web Site: <http://www.grizzlyindustrial.com>

The specifications, drawings, and photographs illustrated in this manual represent the Model G9960 as supplied when the manual was prepared. However, owing to Grizzly's policy of continuous improvement, changes may be made at any time with no obligation on the part of Grizzly. Whenever possible, though, we send manual updates to all owners of a particular tool or machine. Should you receive one, we urge you to insert the new information with the old and keep it for reference.

CAUTION

To operate this, or any power tool, safely and efficiently, it is essential to become as familiar with its characteristics as possible. The time you invest before you begin to use your Model G9960 will be time well spent. DO NOT operate this machine until you are completely familiar with the contents of this manual. Make sure you read and understand all of the safety procedures. If you do not understand something, DO NOT operate the machine.



GETTING TO KNOW YOUR GRINDER

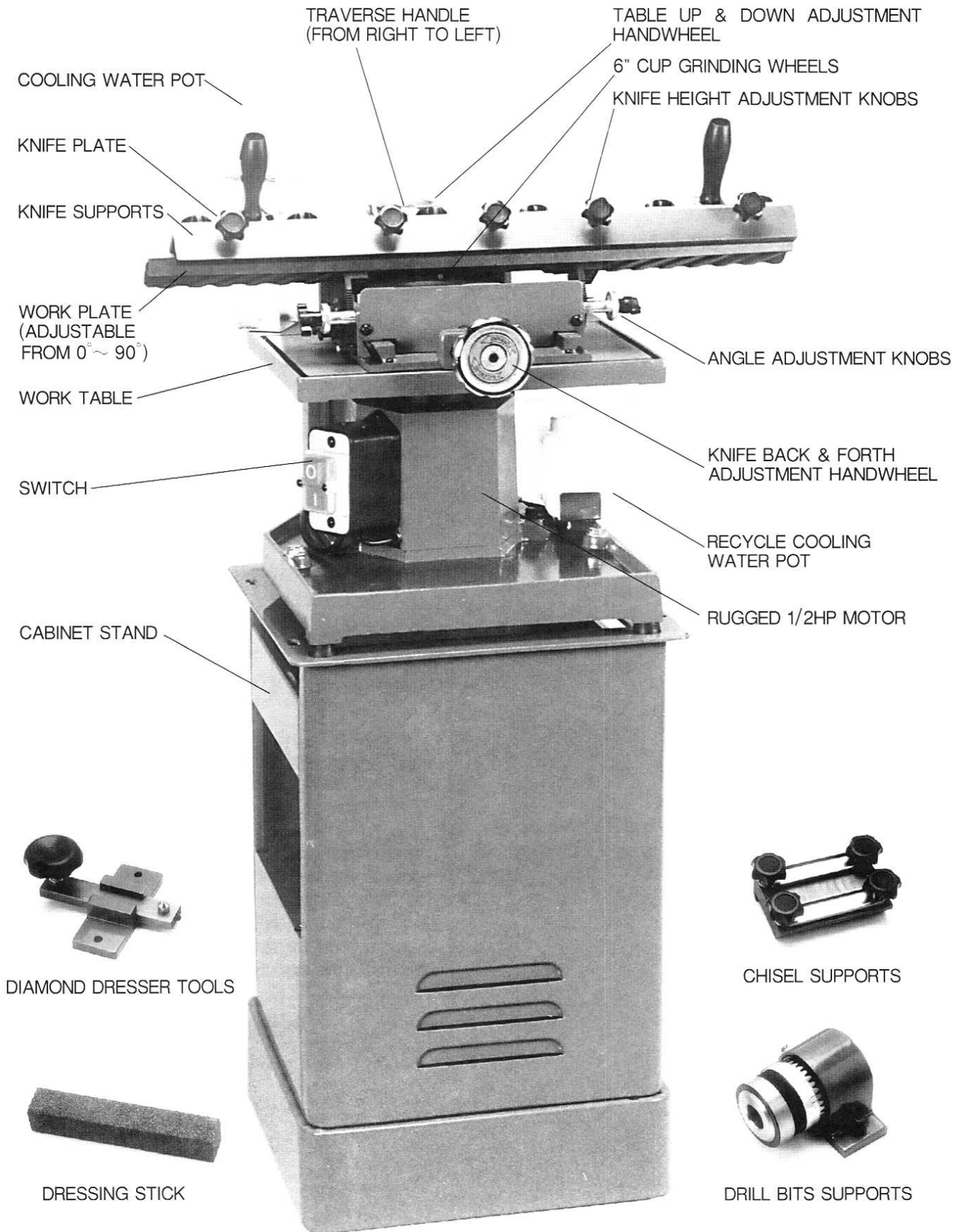

SPECIFICATION

SPECIFICATION

Maximum Knife Length	24"
Maximum Drill Grinding Attachment Capacity	5/8"
Maximum Chisel Width	4"
Straight Cup Grinding Wheel Dimensions	6"X1 1/2 "X5/8"
Grinding Wheel Rotation Speed (R.P.M)	3450
Work Plate Adjustment	0"~90"
Knife Support Traverse Length	25"
Cooling Water Pot Capacity	0.75l
Motor	1/2 HP, 1 PH
Machine Dimensions (L X W X H)	18"X25"X50"
Packing Dimensions (L X W X H) ..Machine... Stand...	16.5"X16.5"X16.5" 15.5"X15.5"X29"
Weight-net/gross .. Machine .. Stand	40/42 KGS 38/40 KGS

Remove all items from the carton. Check the items received against the exploded view drawing in the back of the manual. If any items are missing or were damaged in shipment, please contact us.

TOOLS NEEDED:
 10 m/m Wrench
 12 m/m Wrench
 14 m/m Wrench
 3 m/m Allen Wrench
 5 m/m Allen Wrench
 6 m/m Allen Wrench

NOTICE

A full parts list and breakdown can be found toward the end of this manual. For easier assembly, or to identify missing parts, please refer to the detailed illustrations at the end of the manual.

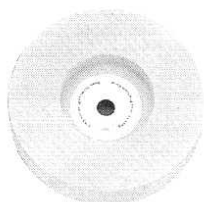

STANDARD ACCESORES:

Rose color aluminum oxide grinding wheels. Suitable for grinding high tensile material such as high speed steel.

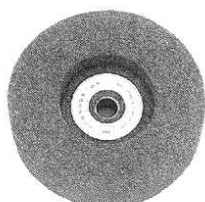

OPTIONAL ACCESORES:

Green color silicon carbide grinding wheels. For special alloy grinding such as tungsten carbide.

OPERATING INSTRUCTIONS

ADJUST THE COOLING WATER.

- After the motor starts, turn on the cooling water control knob to provide a drop of water every few seconds.
- Be aware that the cooling water must be rust-proofed and do not use too much cooling water. One pot of cooling water can be used for three to four hours.

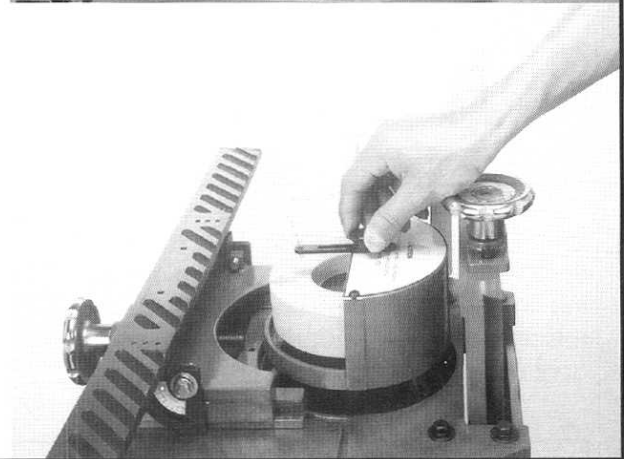
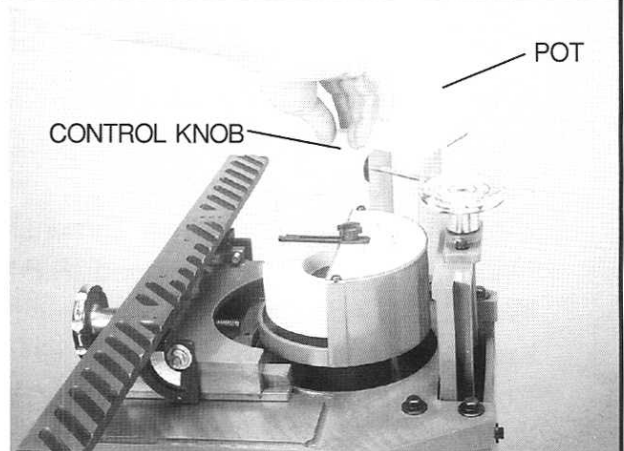

CHANGE GRINDING WHEELS.

Loosen and remove the cover plate using a phillips head screwdriver.

Loosen and remove the grinding wheel flange using a 5 m/m allen wrench.

Remove grinding wheel, replace with new wheel. Remount flange and socket cap screw and tighten with a 5 m/m allen wrench.

CAUTION

Never allow visitors into your shop while assembling, operating, or maintaining tools and machinery. Keep your shop child-safe by locking up securely when not in use, and by providing proper supervision when children are present.

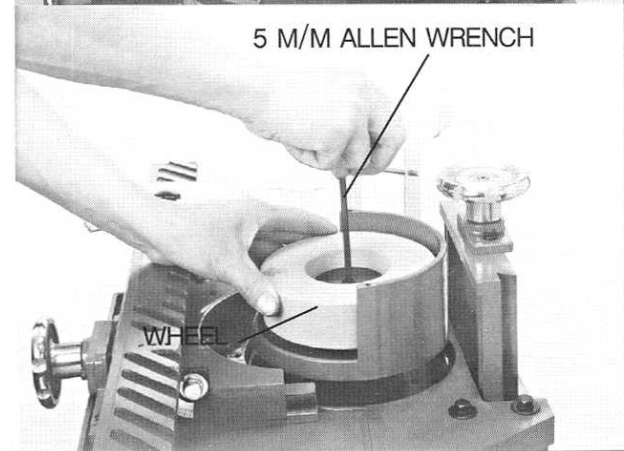
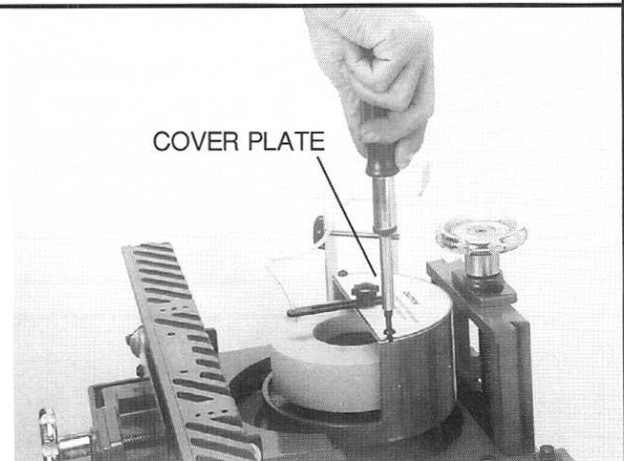

OPERATING INSTRUCTIONS

DRESSING THE GRINDING WHEEL.

After a period of usage, the grinding wheel surface will become loaded and need to be dressed.

To dress the wheel follow the steps outlined below.

A. DRESSING THE SURFACE.

1. Remove the knife support assembly and fix diamond dresser tools onto the work plate and adjust the angle to horizontal 0° degree.
2. Use up & down handwheel to adjust work table until the diamond dresser just touches the surface of grinding wheels.
3. With machine running push the handle of the diamond dresser tool back & forth to dress surface of grinding wheel until the wheel is completely dressed.

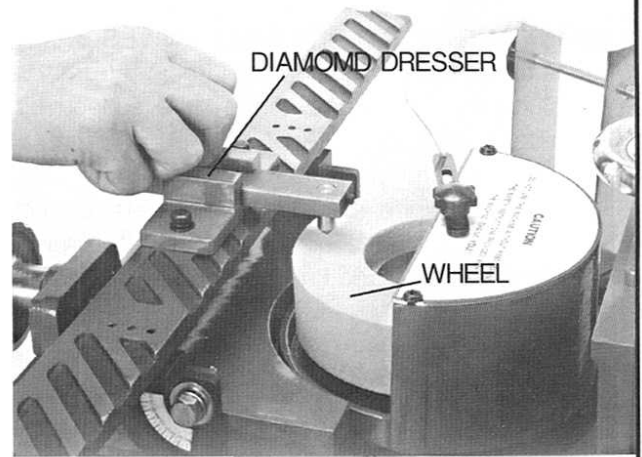

B. DRESSING THE EDGE.

1. Remove the knife support assembly and fix diamond dresser tool onto the work plate and adjust the angle to vertical 90° degree.
2. Use backward & forward handwheel to adjust work plate until the diamond dresser just touches the edge of the grinding wheel.
3. With machine running push the handle of the diamond dresser tool up & down to dress edge of grinding wheel until the wheel is completely dressed.

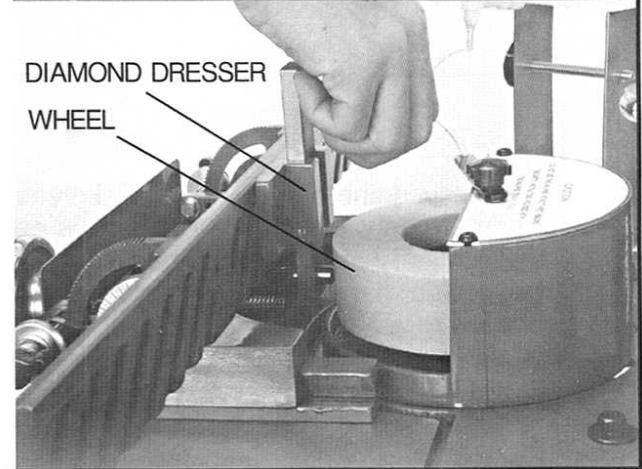

Dressing Stick — most popular general purpose dresser for use on emery wheels.

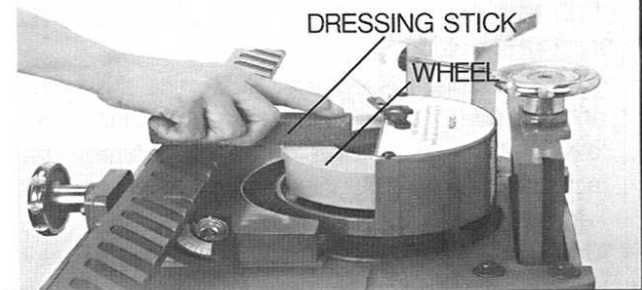

SURFACE & EDGE CUTTING OF THE GRINDING WHEELS.

Use the surface and edges of the grinding wheels. To sharpen both sides of the knife without detaching the knife.

CAUTION

Planer, jointer and other knives are dangerously sharp. Use extreme caution, particularly after sharpening. Failure to exercise care while working near knives could result in severe injury.

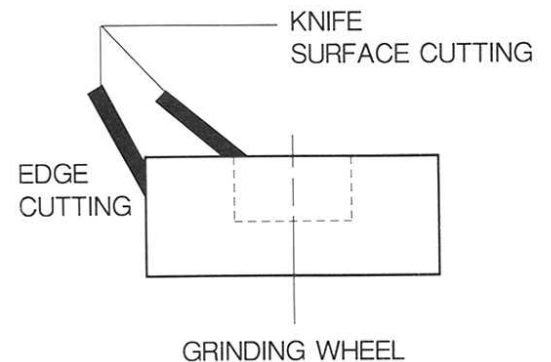

OPERATING INSTRUCTIONS

MOUNTING JOINTER/PLANER KNIVES.

1. Remove the knife lock top plate. Place the dressing tool guide along the front edge of the knife support plate. Adjust the height adjustment knobs until each height adjustment screw just touch the dressing tool guide.
2. Place the knife (beveled edge down) onto the knife support, firmly against the height adjustment screws. Place the knife lock plate onto the knife support and firmly tighten the locking knobs.

NOTE: The knife must be firmly mounted against the height adjustment screws, double check at this time.

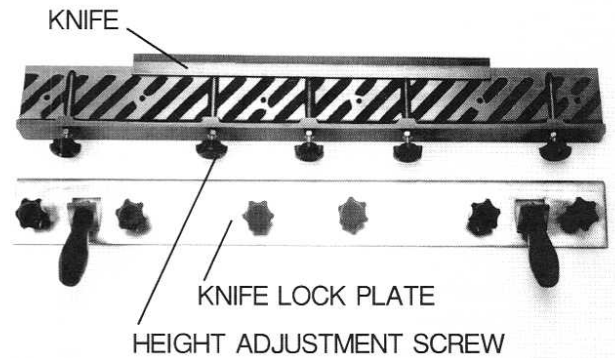

CAUTION

Planer, jointer and other knives are dangerously sharp. Use extreme caution, particularly after sharpening. Failure to exercise care while working near knives could result in severe injury.

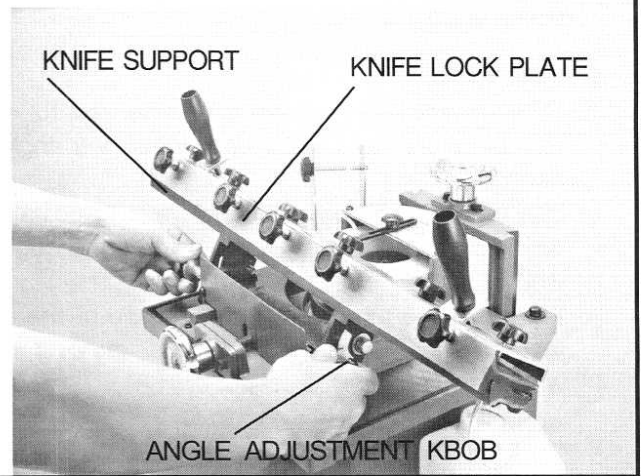

ADJUST THE KNIFE TO THE CORRECT RELIEF & INCLUDED ANGLE.

On most tools it is easy to determine the correct relief and included angle. However on planer and jointer knives there is a wide range of "correct" relief and included angles. The included angle on a planer knife can vary from 30 to 60°.

The woodworker is faced with hundred of varieties of woods, different moisture content and hundreds of molding and planing applications. All these factors can alter the relief and included angles found on planer and jointer knives.

MATCH TO THE EXISTING INCLUDED ANGLE.

With such a wide variety of accepted angles, it would not be wise to change the included angle to a predetermined setting. The best thing to do is match to the existing included angle already on the knife. Mark the beveled edge of the knife with a red marker. As a starting point rotate the pivot plate knob until the knife is held at a 30° angle. Rotate the grinding wheel hand-wheel until the wheel just touches the knife. With the motor off turn the grinding wheel by hand against the knife surface adjust the pivot plate until the grinding wheel will leave marks all the way across the knife edge.

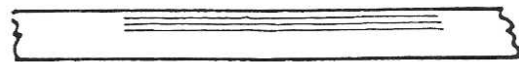
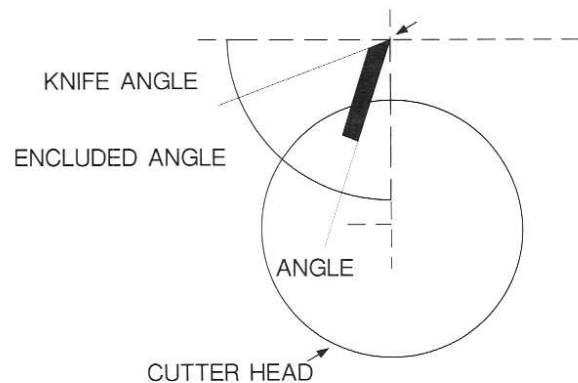

INCORRECT-SCRATCH MARKS ALONG TOP OF BEVEL EDGE



INCORRECT-SCRATCH MARKS ALONG BOTTOM OF BEVELED EDGE



CORRECT-SCRATCH MARKS ALL THE WAY ACROSS BEVELED EDGE

OPERATING INSTRUCTIONS

SHARPEN JOINTER/PLANER KNIVES GRINDING THE KNIFE.

When facing the machine traverse the knife support assembly from the right to the left. Continue to make passes until the knife is sharp and all nicks are removed.

⚠ CAUTION

Use extreme caution when working near cutting surfaces. Failure to exercise care while working near knives could result in severe injury.



SHARPENING CHISELS.

- Remove the knife support assembly and place the chisel support assembly onto work plate.
- Fix chisels onto the chisel support, adjust and experiment with the pivot rotate knob rotate knobs until you have the best supporting angle.
- Adjust the table lower until the chisels just touch the surface of the grinding wheels.
- When facing the machine traverse the chisel support assembly from the right to the left continue to make passes until the chisel is sharpened and all nicks are removed.

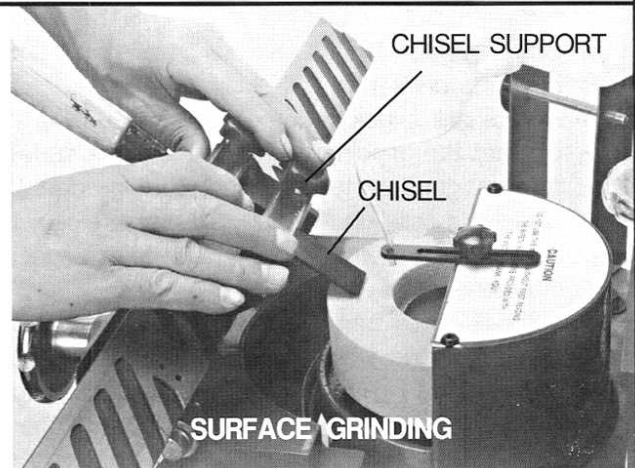

OPERATING INSTRUCTIONS

SHARPENING DRILL BITS

A drill sharpening fixture is included with the G9960 Knife Grinder. The instructions below describe the method for grinding 118^β the most common angle. Other angles may be produced. Consult the proper literature for more information.

1. Remove the knife support assembly and attach the drill grinding fixture onto the knife support rest using the two hex head screws provided. The fixture has a pair of slender keys on one face. Make sure this face is positioned toward the operator.
2. Turn the front handwheel until the knife support rest moves furthest from the grinding wheel.
3. Move the table elevation until it is positioned at the highest possible point. Secure the drill bit into the chuck with the chuck key. Place the drill chuck and drill into the fixture.
4. The keys on the grinding fixture will fit into the cogs on the drill chuck body. Allow them to engage and rotate chuck body counter-clockwise until it stops. Lift drill chuck and turn until one chisel edge of the drill bit is straight down. Allow the keys and cogs to engage.
5. Look at one of the keys in the grinding fixture and use it as a pointer for the degree scale on the side of the drill chuck. Note the angle indicated and write it down for future reference.
6. Loosen the lock knobs and change the angle of the knife support rest to 59^β as indicated on the scale. Retighten knobs.
7. Lower the table until the drill bit just touches the grinding wheel and adjust table down $1/2$ turn.
8. Rotate the drill chuck clockwise until it stops.
9. Start grinder motor. Slowly lower table until grinding wheel contacts drill bit.
10. Rotate drill chuck counter-clockwise until it stops. The bit will contact the grinding wheel on the back surface first and as it rotates, grind up to the chisel cutting edge. Do Not leave drill bit in this position. Rotate drill chuck clockwise to the beginning position. Repeat until drill bit is no longer ground by grinding wheel.
11. Pull drill chuck from grinding fixture and turn off grinder.
12. When grinding wheel comes to a complete stop, reinsert the drill chuck. Find the number on the degree scale that is 180^β from the first indicated setting. Engage the keys and cogs. Rotate the drill chuck counter-clockwise until it stops.
13. Lift drill chuck slightly and start grinder motor. Allow drill chuck to contact grinding wheel and repeat step 10.

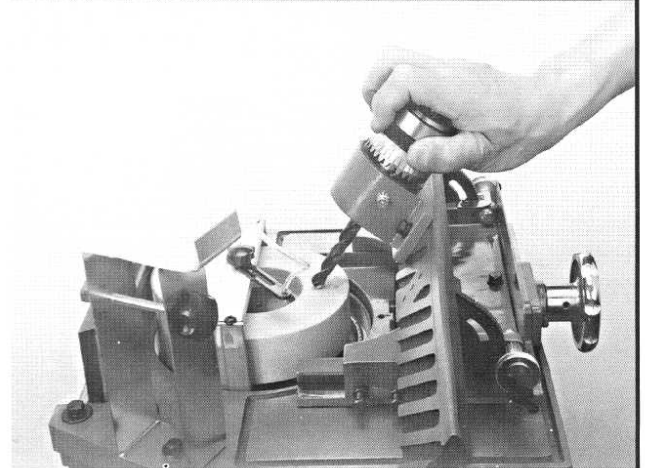
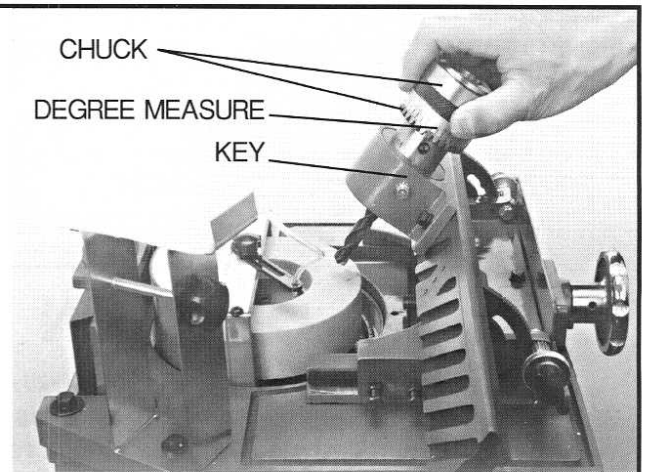

PARTS DIAGRAM

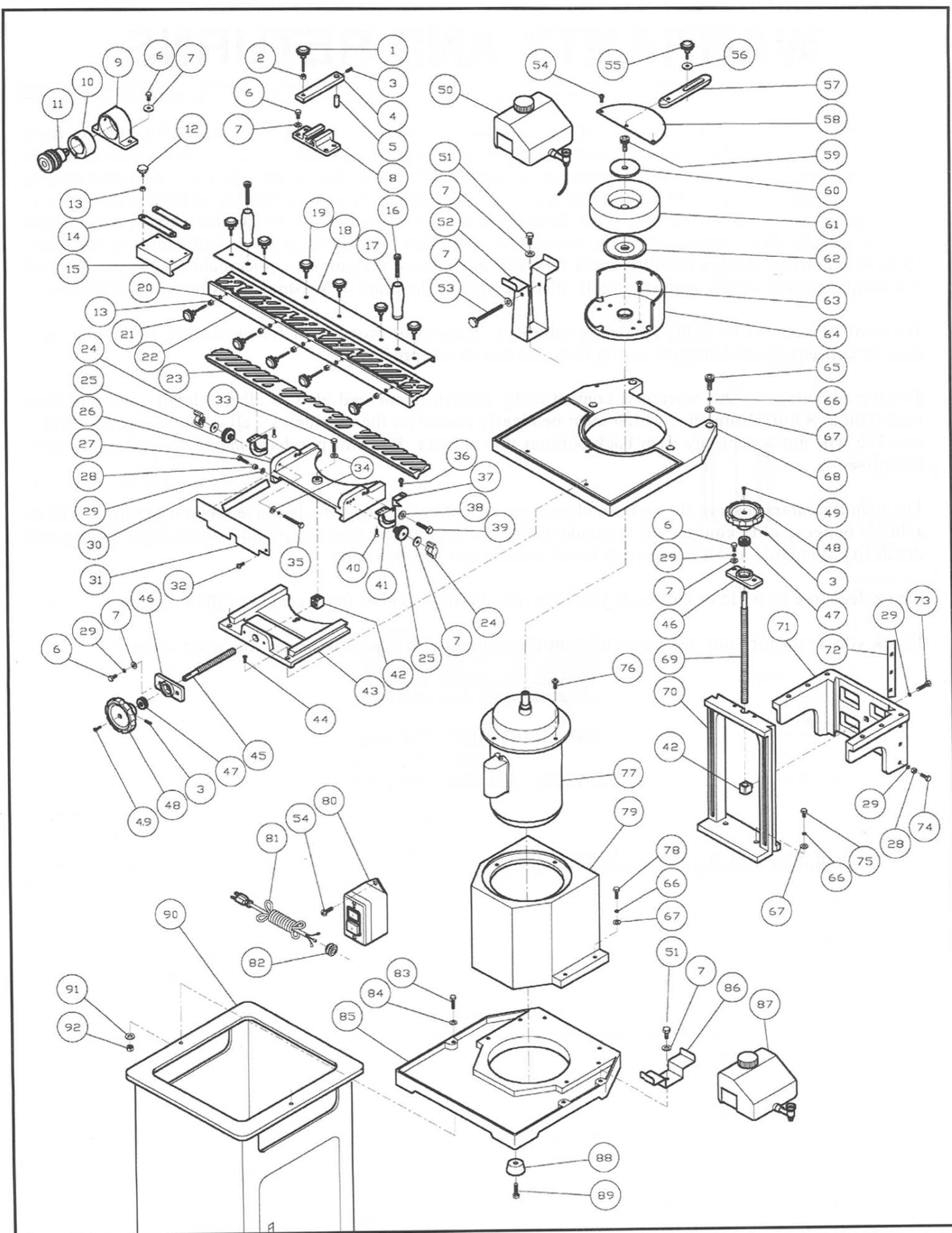

PARTS LIST

DESCRIPTION	Q'TY	DESCRIPTION	Q'TY
1 KNOB	1	47 THRUST BEARING	2
2 HEX JAM NUT	1	48 HAND WHEEL	1
3 SOCKET SET SCREW	3	49 PHILLIPS HEAD SCREW	2
4 DIAMOND DRESSER LOCK PLATE	1	50 WATER POT	1
5 DIAMOND DRESSER	1	51 HEX CAP SCREW	2
6 HEX CAP SCREW	6	52 WATER POT SUPPORT	1
7 WASHER	10	53 KNOB	1
8 DIAMOND DRESSER SUPPORT	1	54 PHILLIPS HEAD SCREW	2
9 CHUCK HOLDER SUPPORT	1	55 KNOB	1
10 CHUCK HOLDER	1	56 WASHER	1
11 CHUCK	1	57 HOSE SUPPORTER	1
12 KNOB	4	58 WHEEL GUARD	1
13 HEX NUT	4	59 SOCKET CAP SCREW	1
14 CHISEL LOCK PLATE	2	60 OUTER FLANGE	1
15 CHISEL SUPPORT	1	61 6" GRINDING WHEEL	1
16 ROUND HEAD SCREW	2	62 INNER FLANGE	1
17 HANDLE	2	63 PHILLIPS ROUND HEAD SCREW	2
18 KNIFE LOCK PLATE	1	64 GRINDING WHEEL HOUSING	1
19 KNOB	6	65 SOCKET CAP SCREW	4
20 O-RING	5	66 SPRING WASHER	10
21 KNOB	5	67 WASHER	10
22 KNIFE SUPPORT	1	68 WORK TABLE	1
23 WORK PLATE	1	69 T-THREAD SCREW	1
24 PIVOT KNOB	2	70 UPPER & DOWN SLIDE GUIDE BASE	1
25 PIVOT ROTATE KNOB	2	71 UPPER & DOWN SLIDE GUIDE	1
26 WORK BRACKET BASE	1	72 PLATE	1
27 HEX CAP SCREW	3	73 HEX CAP SCREW	1
28 HEX NUT	6	74 HEX CAP SCREW	3
29 SPRING WASHER	6	75 HEX CAP SCREW	2
30 PLATE	1	76 PHILLIPS ROUND HEAD SCREW	4
31 COVER PLATE	1	77 MOTOR	1
32 PHILLIPS HEAD SCREW	2	78 HEX CAP SCREW	4
33 HEX CAP SCREW	1	79 MOTOR COVER	1
34 WASHER	3	80 SWITCH	1
35 HEX CAP SCREW	2	81 POWER CARD	1
36 PHILLIPS HEAD SCREW	1	82 CORD BUSH	1
37 POINTER	1	83 HEX CAP SCREW	2
38 WASHER	2	84 WASHER	2
39 HEX CAP SCREW	2	85 BASE	1
40 PHILLIPS HEAD SCREW	4	86 ROD WATER POT SUPPORT	1
41 ANGLE ADJUSTING BASE	2	87 RECYCLE WATER POT SUPPORT	1
42 T-THREAD UNT	1	88 RUBBER SUPPORT FEET	4
43 SLIDE GUIDE	1	89 HEX CAP SCREW	4
44 PHILLIPS ROUND HEAD SCREW	3	90 CABINET STAND	1
45 T-THREAD SCREW	1	91 WASHER LOMM	2
46 BEARING BASE	2	92 HEX JAM UNT	2

WARRANTY AND RETURNS

Grizzly Industrial, Inc. warrants every product it sells for a period of **1 year** to the original purchaser from the date of purchase. This warranty does not apply to defects due directly or indirectly to misuse, abuse, negligence, accidents, repairs or alterations or lack of maintenance. This is Grizzly's sole written warranty and any and all warranties that may be implied by law, including any merchantability or fitness, for any particular purpose, are hereby limited to the duration of this written warranty. We do not warrant or represent that the merchandise complies with the provisions of any law or acts unless the manufacturer so warrants. In no event shall Grizzly's liability under this warranty exceed the purchase price paid for the product and any legal actions brought against Grizzly shall be tried in the State of Washington, County of Whatcom.

We shall in no event be liable for death, injuries to persons or property or for incidental, contingent, special, or consequential damages arising from the use of our products.

To take advantage of this warranty, contact us by mail or phone and give us all the details. We will then issue you a Return Number, which must be clearly posted on the outside as well as the inside of the carton. We will not accept any item back without this number. Proof of purchase must accompany the merchandise.

The manufacturers reserve the right to change specifications at any time because they constantly strive to achieve better quality equipment. We make every effort to ensure that our products meet high quality and durability standards and we hope you never need to use this warranty.

Please feel free to write or call us if you have any questions about the machine or the manual.

Thank you again for your business and continued support. We hope to serve you again soon.

WARRANTY CARD

Name _____
Street _____
City _____ State _____ Zip _____
Phone Number _____ E-Mail _____ FAX _____
MODEL #G9960 24" Wet & Dry Cutting Tool Grinder Order # _____

The following information is given on a voluntary basis. It will be used for marketing purposes to help us develop better products and services. Of course, all information is strictly confidential.

1. How did you learn about us?

- Advertisement Friend
 Catalog Card Deck
 World Wide Web
 Other _____

2. Which of the following magazines do you subscribe to.

- American Woodworker Practical Homeowner
 Cabinetmaker Shop Notes
 Family Handyman Today's Homeowner
 Fine Homebuilding WOOD
 Fine Woodworking Wooden Boat
 Home Handyman Woodshop News
 Journal of Light Construction Woodsmith
 Old House Journal Woodwork
 Popular Mechanics Woodworker
 Popular Science Woodworker's Journal
 Popular Woodworking Workbench
 Other _____

3. Which of the following woodworking/remodeling shows do you watch?

- Backyard America The New Yankee Workshop
 Home Time This Old House
 The American Woodworker Woodwright's Shop
 Other _____

4. What is your annual household income?

- \$20,000-\$29,999 \$60,000-\$69,999
 \$30,000-\$39,999 \$70,000-\$79,999
 \$40,000-\$49,999 \$80,000-\$89,999
 \$50,000-\$59,999 \$90,000 +

5. What is your age group?

- 20-29 50-59
 30-39 60-69
 40-49 70 +

6. How long have you been a woodworker?

- 0 - 2 Years 8 - 20 Years
 2 - 8 Years 20+ Years

7. How would you rank your woodworking skills?

- Simple Advanced
 Intermediate Master Craftsman

8. What stationary woodworking tools do you own? Check all that apply.

- Air Compressor Panel Saw
 Band Saw Planer
 Drill Press Power Feeder
 Drum Sander Radial Arm Saw
 Dust Collector Shaper
 Horizontal Boring Machine Spindle Sander
 Jointer Table Saw
 Lathe Vacuum Veneer Press
 Mortiser Wide Belt Sander
 Other _____

9. How many of your woodworking machines are Grizzly? _____

10. Which benchtop tools do you own? Check all that apply.

- 1" x 42" Belt Sander 6" - 8" Grinder
 5" - 8" Drill Press Mini Lathe
 8" Table Saw 10" - 12" Thickness Planer
 8" - 10" Bandsaw Scroll Saw
 Disc/Belt Sander Spindle/Belt Sander
 Mini Jointer
 Other _____

11. How many of the machines checked above are Grizzly? _____

12. Which portable/hand held power tools do you own? Check all that apply.

- Belt Sander Orbital Sander
 Biscuit Joiner Palm Sander
 Circular Saw Portable Planer
 Detail Sander Saber Saw
 Drill/Driver Reciprocating Saw
 Miter Saw Router
 Other _____

13. What machines/supplies would you like Grizzly Industrial to carry?

- 12" Table Saw Radial Arm Saw
 12" Jointer Panel Saw
 Combination Planer/Jointer Brass Hardware
 Paint & Finishing Supplies Lumber
 Contractor's Supplies
 Other _____

14. What new accessories would you like Grizzly Industrial to carry?

- Builders Hardware Hand Tools
 Fasteners Wood Components
 Other _____

15. What other companies do you purchase your tools and supplies from?

16. Do you think your purchase represents good value?

- Yes No

17. Would you recommend Grizzly Industrial to a friend?

- Yes No

18. Would you allow us to use your name as a reference for Grizzly customers in your area? **Note: We never use names more than three times.**

- Yes No

19. Comments: _____

